



# "Pasta Magic" Gas Water Cooker (GWC) Parts Manual



Frymaster, a member of the Commercial Food Equipment Service Association, recommends using CFESA Certified Technicians.

**24-Hour Service Hotline**  
**1-800-551-8633**

[www.frymaster.com](http://www.frymaster.com)

E-mail: [service@frymaster.com](mailto:service@frymaster.com)

Original Instructions



12/2015

**NOTICE**

IF, DURING THE WARRANTY PERIOD, THE CUSTOMER USES A PART FOR THIS MANITOWOC FOOD SERVICE EQUIPMENT OTHER THAN AN UNMODIFIED NEW OR RECYCLED PART PURCHASED DIRECTLY FROM FRYMASTER OR ANY OF ITS AUTHORIZED SERVICERS, AND/OR THE PART BEING USED IS MODIFIED FROM ITS ORIGINAL CONFIGURATION, THIS WARRANTY WILL BE VOID. FURTHER, FRYMASTER AND ITS AFFILIATES WILL NOT BE LIABLE FOR ANY CLAIMS, DAMAGES OR EXPENSES INCURRED BY THE CUSTOMER WHICH ARISE DIRECTLY OR INDIRECTLY, IN WHOLE OR IN PART, DUE TO THE INSTALLATION OF ANY MODIFIED PART AND/OR PART RECEIVED FROM AN UNAUTHORIZED SERVICER.

**NOTICE**

This appliance is intended for professional use only and is to be operated by qualified personnel only. A Frymaster Factory Authorized Servicer (FAS) or other qualified professional should perform installation, maintenance, and repairs. Installation, maintenance, or repairs by unqualified personnel may void the manufacturer's warranty. See Chapter 1 of this manual for definitions of qualified personnel.

**NOTICE**

This equipment must be installed in accordance with the appropriate national and local codes of the country and/or region in which the appliance is installed. See NATIONAL CODE REQUIREMENTS in Chapter 2 of this manual for specifics.

**NOTICE TO U.S. CUSTOMERS**

This equipment is to be installed in compliance with the basic plumbing code of the Building Officials and Code Administrators International, Inc. (BOCA) and the Food Service Sanitation Manual of the U.S. Food and Drug Administration.

**NOTICE**

Drawings and photos used in this manual are intended to illustrate operational, cleaning and technical procedures and may not conform to onsite management operational procedures.

**NOTICE**

This appliance is intended to be used for commercial applications, for example in kitchens of restaurants, canteens, hospitals and in commercial enterprises such as bakeries, butcheries, etc., but not for continuous mass production of food.

 **DANGER**

Improper installation, adjustment, maintenance or service, and unauthorized alterations or modifications can cause property damage, injury, or death. Read the installation, operating, and service instructions thoroughly before installing or servicing this equipment. Only qualified service personnel may convert this appliance to use a gas other than that for which it was originally configured.

 **DANGER**

No structural material on the cooker should be altered or removed to accommodate placement of the cooker under a hood. Questions? Call the Frymaster Service Hotline at 1-800-551-8633.

 **WARNING**

After installation of a gas cooker and after any maintenance to the gas system of a gas cooker-manifold, valve, burners, etc. – check for gas leaks at all connections. Apply a thick soapy solution to all connections and ensure there are no bubbles. There should be no smell of gas.

**NOTICE**

The Commonwealth of Massachusetts requires any and all gas products to be installed by a licensed plumber or pipe fitter.

 **DANGER**

Adequate means must be provided to limit the movement of this appliance without depending upon the gas line connection. Single cookers equipped with legs must be stabilized by installing anchor straps. All cookers equipped with casters must be stabilized by installing restraining chains. If a flexible gas line is used, an additional restraining cable must be connected at all times when the cooker is in use.

 **CAUTION**

No warranty is provided for any Frymaster cooker used in a mobile or marine installation or concession. Warranty protection is only offered for cookers installed in accordance with the procedures described in this manual. Mobile, marine or concession conditions of this cooker should be avoided to ensure optimum performance.

 **DANGER**

The front ledge of the cooker is not a step! Do not stand on the cooker. Serious injury can result from slips or contact with the hot water.

 **DANGER**

Do not store or use gasoline or other flammable liquids or vapors in the vicinity of this or any other appliance.

 **DANGER**

Do not spray aerosols in the vicinity of this appliance while it is in operation.

 **DANGER**

Instructions to be followed in the event the operator smells gas or otherwise detects a gas leak must be posted in a prominent location. This information can be obtained from the local gas company or gas supplier.

 **DANGER**

Improper installation, adjustment, maintenance or service, and unauthorized alterations or modifications can cause property damage, injury, or death. Read the installation, operating, and service instructions thoroughly before installing or servicing this equipment.

 **DANGER**

Prior to movement, testing, maintenance and any repair on your Frymaster cooker; disconnect ALL electrical power cords from the electrical power supply.

 **WARNING**

Use caution and wear appropriate safety equipment to avoid contact with hot water or surfaces that may cause severe burns or injury.

 **WARNING**

Do not use deliming solution to clean water bath units. Use of deliming solution will damage all stainless steel parts.

**THIS PAGE INTENTIONALLY LEFT BLANK**

# PASTA MAGIC GAS WATER COOKER

## PARTS MANUAL

### TABLE OF CONTENTS

---

#### CHAPTER 1: Parts List

1.1	Accessories.....	1-1
1.2	Sides, Door, Casters, Switches and Associated Components .....	1-2
1.3	Combustion System Components.....	1-3
1.4	Control Box and Related Components.....	1-5
1.5	Drain Components.....	1-7
1.6	Gas Supply System Components.....	1-8
1.7	Water Supply Components.....	1-10

# PASTA MAGIC GAS WATER COOKER GWC PARTS

## CHAPTER 1: PARTS LIST

### 1.1 Accessories

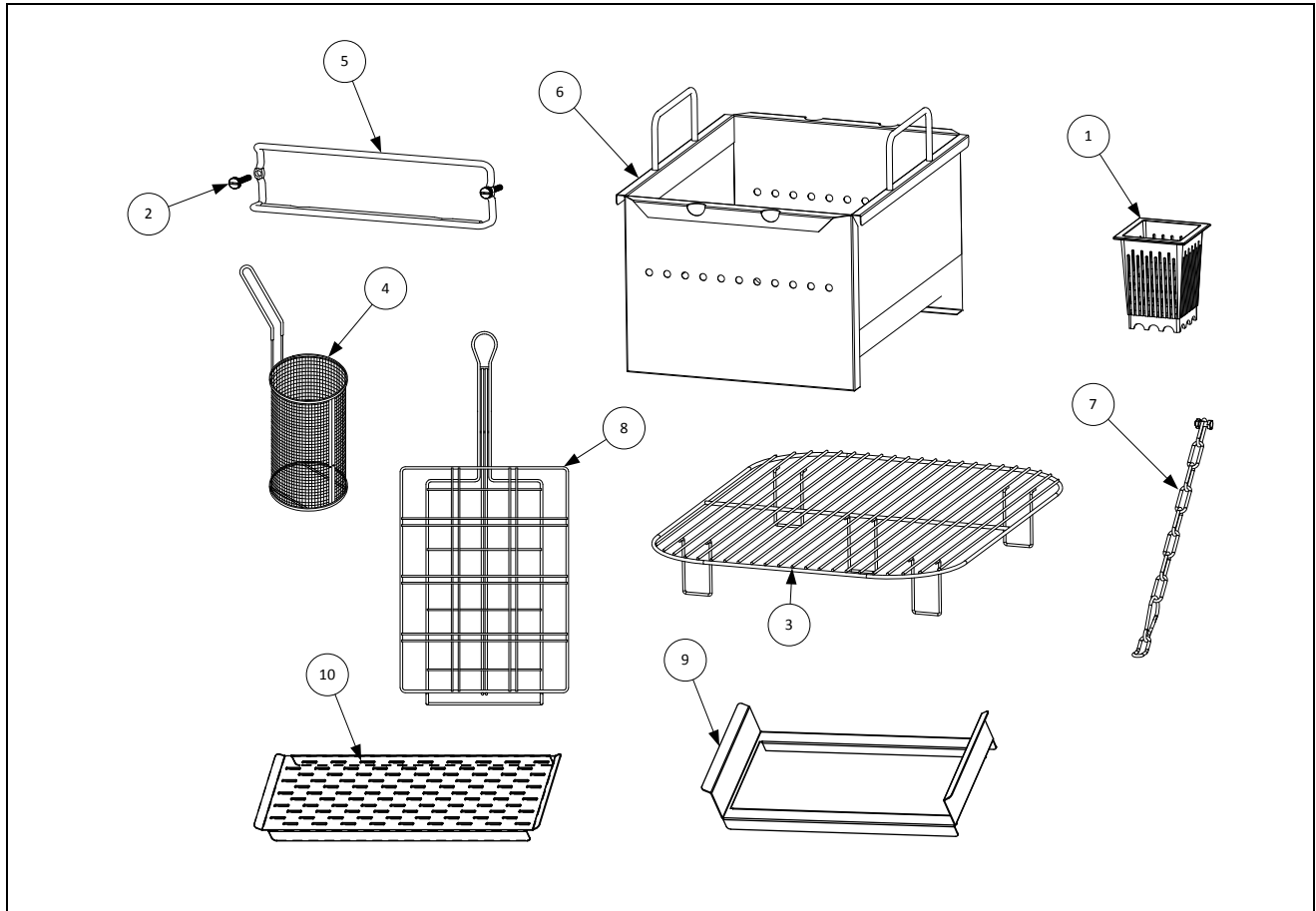

ITEM	PART #	COMPONENT
1	8030018	Cup, Single Pasta Portion (Beige)
2	8102229	Hanger, Wire-Form Basket
3	8030205	Rack, Support
4	8030238	Basket, 5½ x 8½ SS Round Pasta
5	8090985	Thumbscrew, ¼-20 x 1⅝
6	8237384	Basket, Pasta Bulk
7	8260900	Kit, Chain Restraint
8	8030200	Rack, 12 Portion Cup (holds 12 of item #1)
9	2105068	Insert, Pan
10	9102545	Shelf, Front Drain

## 1.2 Sides, Door, Casters, Switches and Associated Components

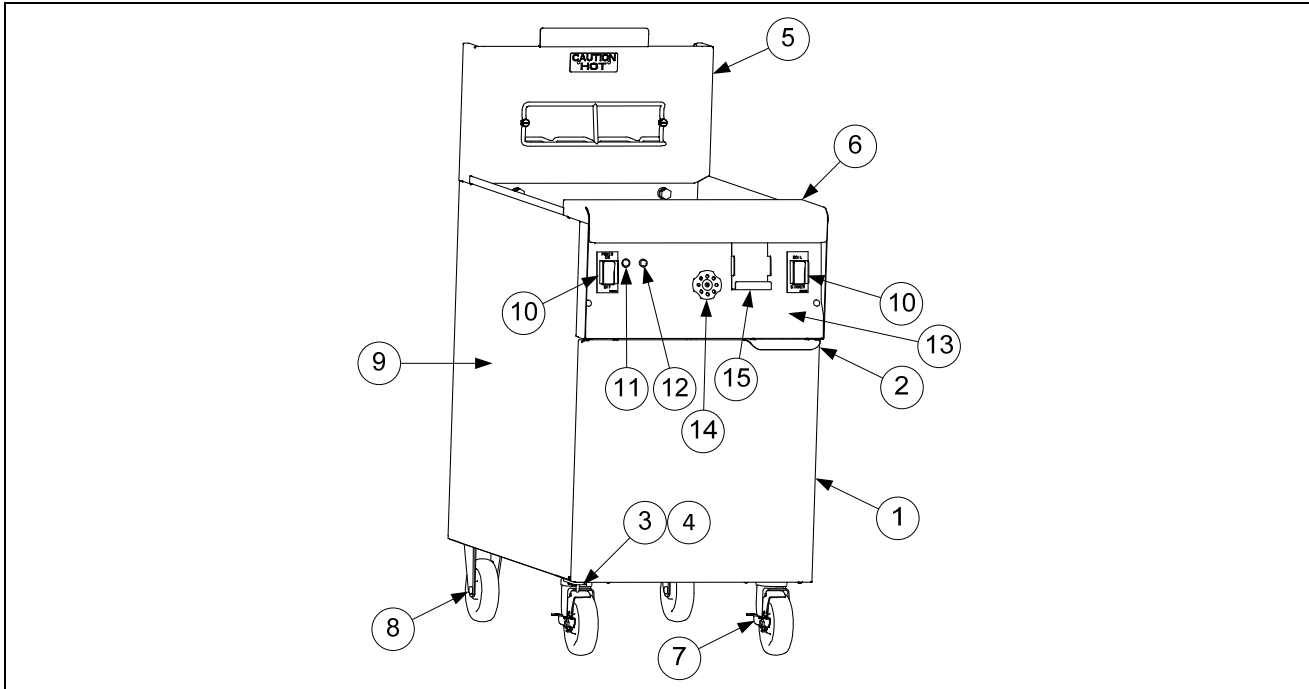

ITEM	PART #	COMPONENT
1	1081434	Door Assembly, 18.66-inch x 19.85-inch (does not include handle)
	1064067	Door Pin Assembly
	8261343	Spring, Door Hinge (Pkg. of 10)
2	2304963	Handle, Wireform Door
3	8090193	Washer, ¼-inch Nylon Flat
4	2307192	Hinge, Universal Door
*	8101105	Magnet, Door
5	1084257	Flue Cap and Insulation Assembly
	8238517	Flue Cap
	8160169	Insulation, 8.12-inch x 18-inch x .25-inch Flue Cap
	2309789	Retainer, Flue Cap Insulation
6	8242120	Topcap
7	8261118	Caster w/Brake (includes mounting hardware)
8	8261117	Caster w/o Brake (includes mounting hardware)
9	2316969	Side, Cabinet Left SS
*	2326969	Side, Cabinet Right SS
*	1081825	Back, Upper GPC Single Cabinet
*	1081826	Back, Lower GPC Single Cabinet
10	8073579	Switch, 6 Prong Carling
11	8074112	Light, Green Indicator
12	8075309	Light, Amber Indicator
13	2600621	Fascia
14	8102684	Valve, Water Plastic ½" with Handle
15	2601200	Cradle, Timer Bracket

\* Not illustrated.

### 1.3 Combustion System Components

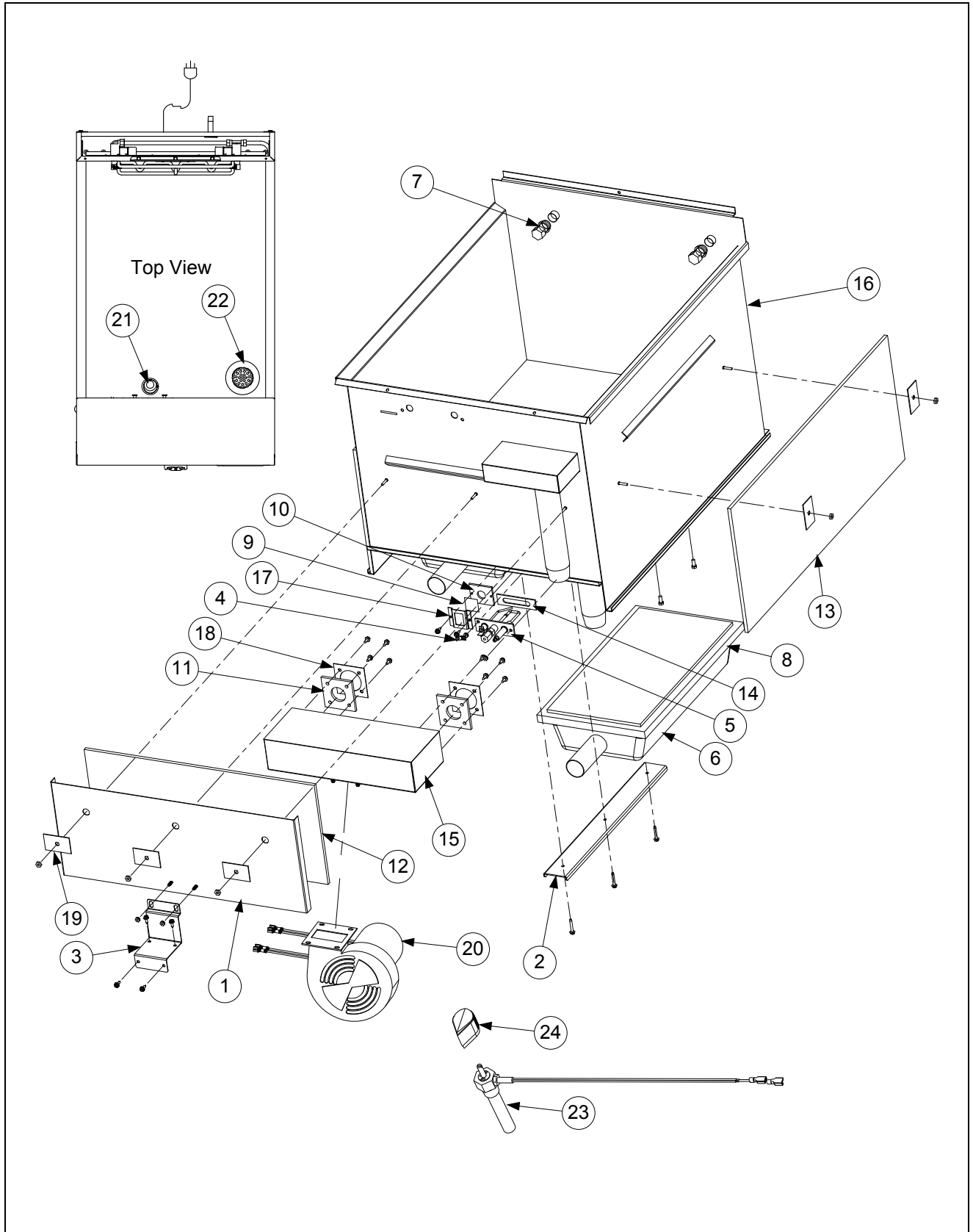



### 1.3 Combustion System Components cont.

ITEM	PART #	COMPONENT
		Cookpot Complete Assemblies (does not include blower (see item 20))
	1081420SP	GPC Natural Gas
	1081422	GPC Propane
	1086095	GPC Natural Gas
	1086096	GPC Propane
1	1086518	Support Assembly, Plenum
2	2206994	Bracket, Retainer Burner
3	2206995	Bracket, Support Plenum
4	8070037	Tab, Faston
5		Ignitor
	8260981	Natural Gas
	8260982	Propane Gas
6	8261072	Burner, Universal Replacement
		Orifice, Burner
*	8100386	2.10mm Propane/Butane (G30,G31) (0-4999 Ft., 0-1524M)
*	8100403	3.40mm Natural Gas (G20, G25) (0-4999 Ft., 0-1524M)
*	8100437	3.60mm Natural Gas (G20, G25) (5000 – 6999Ft., 1525-2133M)
7	8100976	Nozzle, Water Inlet
8	8160924	Insulation, Burner 14.40 inches
*	8160923	Insulation, Burner 18.00 inches
9	8140048SP	Glass, Site
10	8160053	Insulation, Site Glass
11	8160057	Gasket, Plenum H50
*	8160145	Insulation, Pot Side FBR 18
*	8160166	Insulation, Rear Bottom GSMS
12	8161034	Insulation, Front SMSG
13	8160153	Insulation, 10x24x.25 GSMS Cookpot Side
14	8160165	Insulation, Ignitor GSMS
15	8237591	Plenum Assembly GPC
16	8237590	Cookpot GPC
	8238860	Cookpot GPC
17	9001031	Retainer, Sight Glass
18	9001049	Retainer, Plenum Gasket
19	9001762	Insulation, Retainer
20		Motor, Blower
	1081540	120VAC/60 Hz
	8071712	230VAC 50/60 Hz
21	1086713	Switch, Float GWC
22	8232022	Strainer Assy
*	2600798	Guard, Probe/Float
23	1086199	Thermostat, GWC
24	8100110	Knob, Thermostat
*	8023160	Label, Thermostat Dial Plate

\*Not illustrated.

### 1.4 Control Box and Related Components

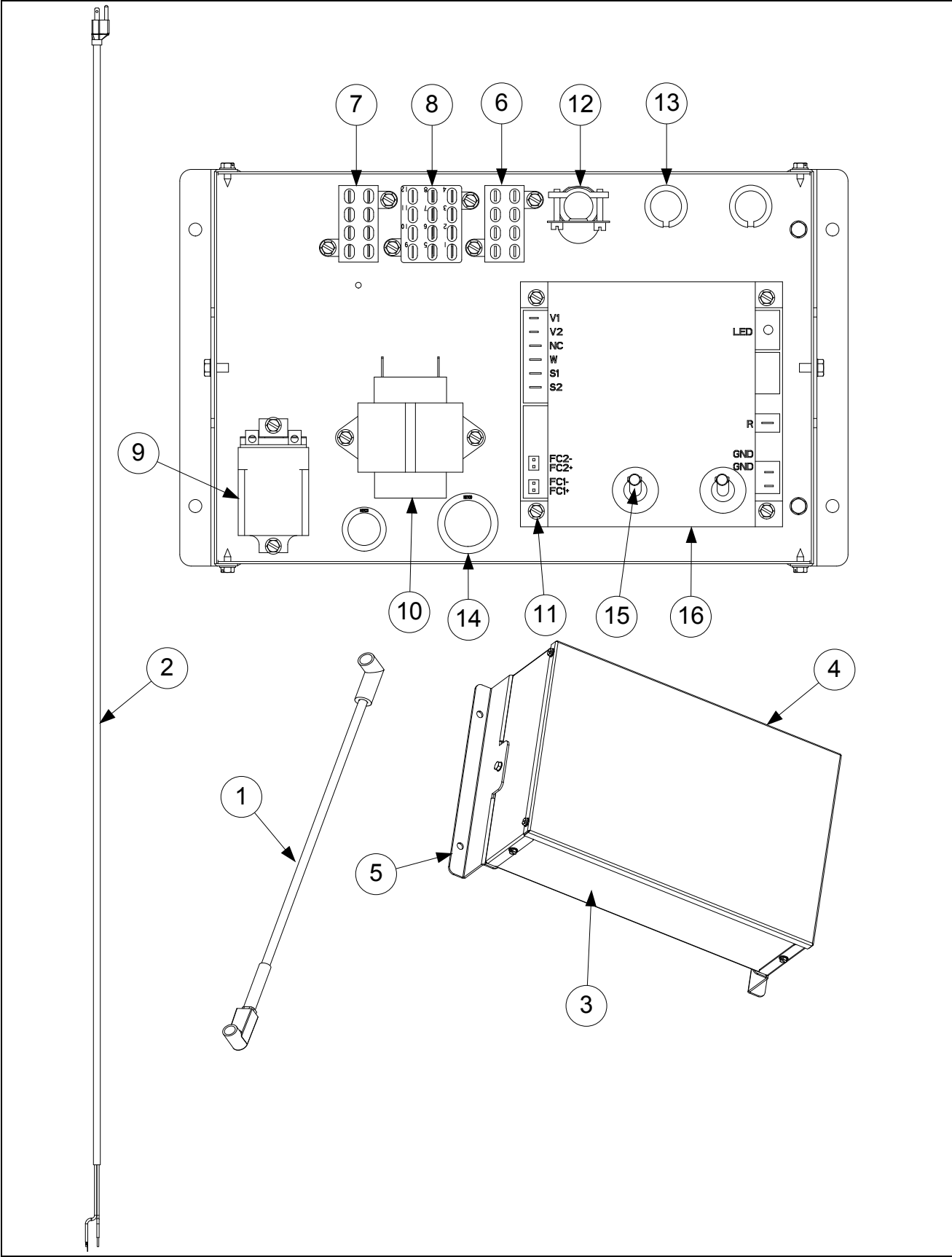

#### 1.4 Control Box and Related Components cont.

ITEM	PART #	COMPONENT
		Component Assembly Boxes
	1081506	Component Box Assy, 120V Non-BL GPC
	1081546	Component Box Assy, 230V Non-BL GPC
1	1060677SP	Cable, Ignition 36" (used with Item 16 – also requires Item 15) (two required for each 8074943 Ignition Module)
*	W1C585SP	Flame sensor wire
2		Cordset
	1081541	120VAC (illustrated)
	1081547	208-240VAC (not illustrated)
3	2309699	Box, Component
4	2309701	Cover, Box Component
5	2309700	Mount, Component Box
6	8070067	Block, Terminal 8 pin
7	8070255	Terminal Strip
8	8070276	Block, Terminal 20-pin
9	8070670	Relay, DPDT 24V Heat Relay
10		Transformer
	8070800	120VAC/24VAC, 50/60 Hz, 50VA
	8070680	208-240VAC/24VAC, 50/60 Hz, 20VA
11	8100045	Bushing, .875 Hole 11/16
12	8071612	Clamp, 3/8 Connector
13	8071926	Bushing, Split .875
14	8072469	Bushing, Heyco 1" ID
15	8073484	Connector, Rajah (two required for each 8074943 Ignition Module)
16	8074943	Module, Fenwal Pasta Dual-Spark FV Ignition
*	WIR0944	Wiring Assembly, 120V
*	WIR0945	Wiring Assembly, 208-240V
*	WIR1107	Wiring Assembly, 120V Noodles w/ Thermostat
*	1081539	Harness, Computer/Component Non-Basket Lift GPC

\* Not illustrated.

## 1.5 Drain Components

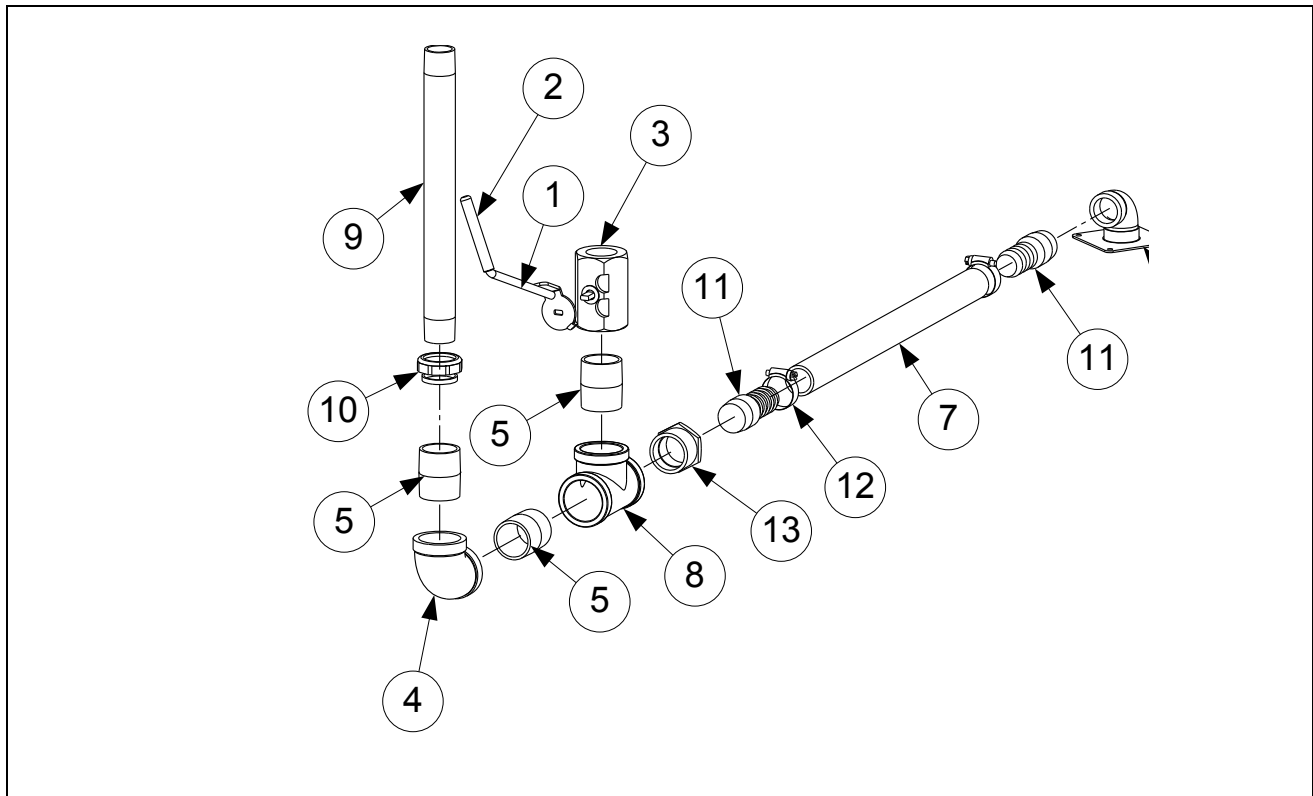

ITEM	PART #	COMPONENT
1	8237996	Handle, Drain Valve GPC
2	8160639	Cap, Vinyl Red 5/16" x 3 inch
3	8101825	Valve, 1 1/4-inch x 1 1/4-inch SS Drain
4	8130994	Elbow, 1 1/4-inch NPT 90° Galv.
5	8130996	Nipple, 1 1/4-inch NPT Close
6	8238495	Plate, Welded Assembly, Drain GPC
7	8160852	Hose, Drain GPC 16 1/2 -inch
8	8130997	Tee, 1 1/4-inch Galv.
9	8130451	Nipple, 1 1/4-inch BM x 12-inch Chrome/Brass
10	8130453	Nut, Slip 1 1/4-inch Chrome/Stainless
11	8130525	Fitting, Barb 1-inch to Hose
12	8090374	Clamp, Hose
13	8130998	Bushing, 1-inch x 1 1/4-inch Hex Galv.

## 1.6 Gas Supply System Components

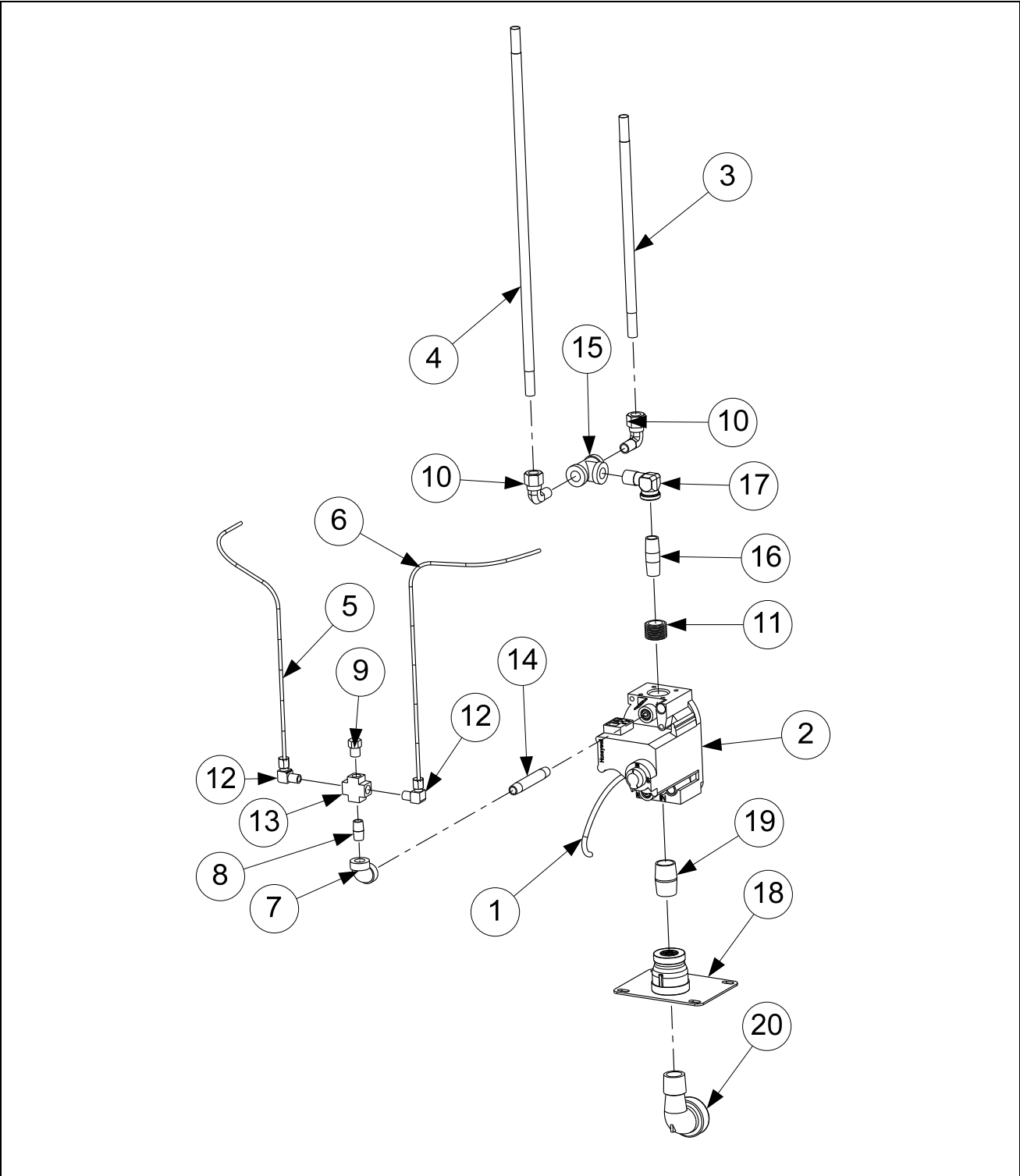

## 1.6 Gas Components cont.

ITEM	PART #	COMPONENT
1	8100691	Tube, Vent
2		Valve, Honeywell Gas (Non-CE)
	8261122	Natural
	8261123	Propane Gas
3	8101353	Flexline, 3/8-inch x 9 inch SS
4	8101355	Flexline, 3/8-inch x 15 inch SS
5	8110800	Tube, 12.50-inch Enrichment (See <b>NOTE 1</b> .)
6	8111197	Tube, 18-inch Enrichment (See <b>NOTE 1</b> .)
7	8131008	Elbow, 1/8-inch NPT 90° SS
8	8131009	Nipple, 1/8-inch NPT x Close SS
9	8131007	Plug, 1/8-inch Hex Head SS
10	8131026	Elbow, 1/4-inch NPT x 3/8-inch Tube Brass
11	8131010	Bushing, 1/2-inch to 1/4-inch Flush SS
12	8130354	Elbow, 90° 1/8-inch NPT x 1/8-inch Tube Brass
13	8130378	Fitting, 1/8-inch NPT Female Cross
14	8131011	Nipple, 1/8-inch NPT x 2.50-inch SS
15	8131028	Tee, 1/4 -inch NPT Brass
16	8130471	Nipple, 1/4-inch NPT x 1.50-inch Brass
17	8131029	Elbow, 1/4-inch Brass Street
18	8238500	Mount Welded Assembly, Gas Valve GPC
*	8069678SP	Plug, CE Honeywell Gas Valve
**	8101041	Kit, CE Valve Accessory
19	8130900	Nipple, 1/2-inch x Close NPT SS
20	8130168	Elbow, Street 90° 3/4-inch x 3/4-inch NPT BM
*	8101715	Valve, Honeywell CE Gas (Natural or Propane)

\* Not illustrated.

\*\* Contains straight and elbow flanges, o-rings, and screws for mounting flanges to valve.

**NOTE 1:** Items 5 and 6 are delivered straight and must be formed by the installer to fit the unit.

## 1.7 Water Supply System Components

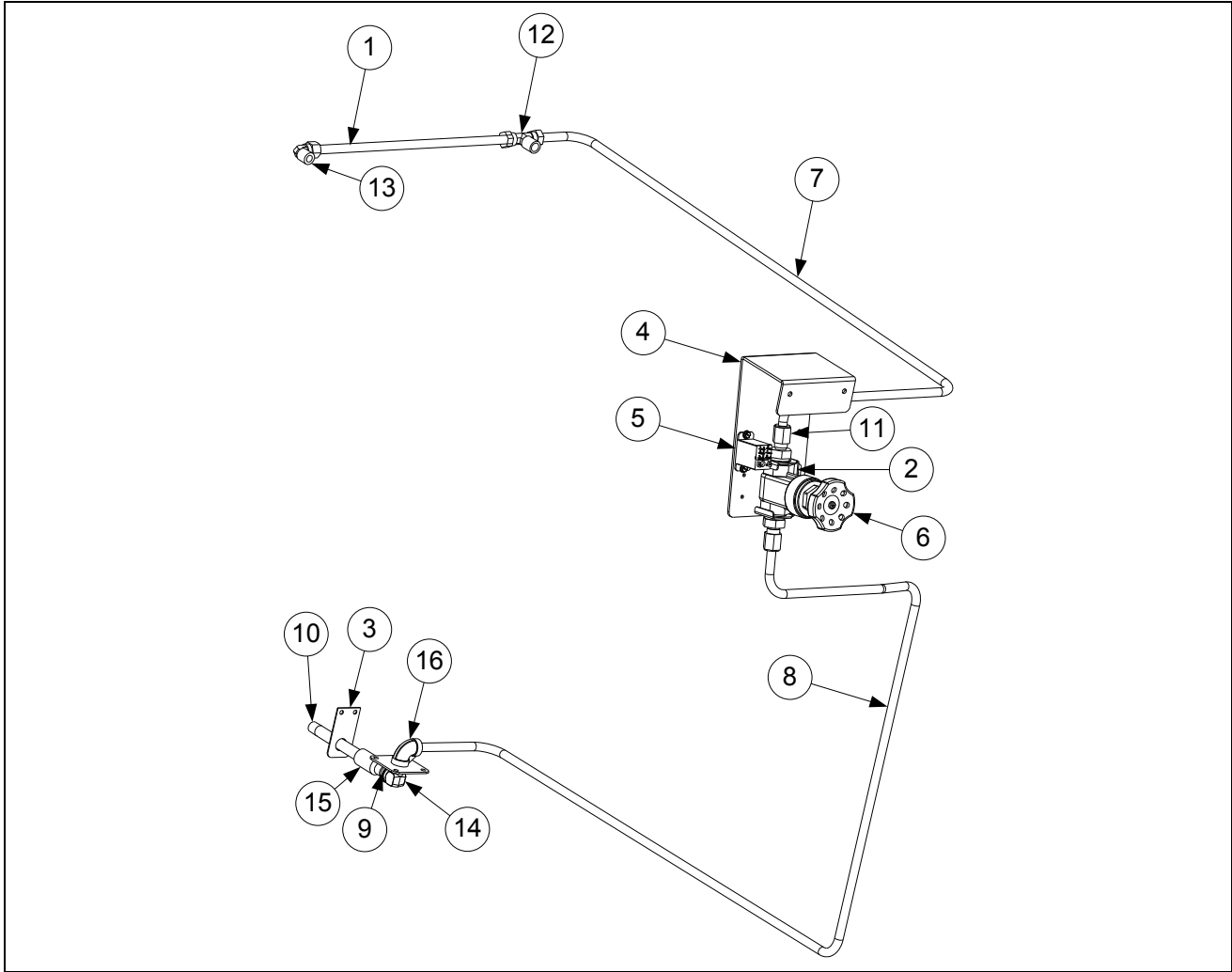

ITEM	PART #	COMPONENT
1	2205387	Tube, Cookpot Water (GPC )
2	2207295	Bracket, Water Valve (GPC )
3	2309709	Bracket, Support Water Line GPC
4	2400787	Bracket, Center-Mount Water Valve
5	8074114	Relay, 24VAC Coil (Float Switch Relay)
6	8102684	Valve, 1/2 -inch Water (GPC )
7	8104424	Tubing, Water Outlet GWC T-Stat
8	8104425	Tubing, Water Inlet GWC T-Stat
9	8130471	Nipple, 1/4-inch NPT x 1.5-inch Brass
10	8130473	Nipple, 1/4-inch NPT x 4.0-inch Brass
11	8130852	Fitting, CC 1/2-inch NPT x 3/8-inch Tube Brass
12	8131023	Tee, 3/8-inch NPT Male X 3/8-inch Tube Brass
13	8131024	Elbow, 3/8-inch NPT x 3/8-inch Tube Brass
14	8131029	Elbow, 1/4-inch NPT Brass Street
15	8131030	Coupling, 1/4-inch NPT Brass
16	8237595	Mount, W/A Water Inlet GPC



Shipping Address: 8700 Line Avenue, Shreveport, Louisiana 71106

TEL 1-318-865-1711

(Tech Support) 1-318-219-7135

PRINTED IN THE UNITED STATES

SERVICE HOTLINE  
1-800-551-8633

Price: \$8.00  
8197237

12/2015